

WDP Angel Owner's Manual

This is an exact replication of the WDP Angel™ Owner's Manual. I recieved permission from WDP before duplicating this manual. Although all the text is property of WDP, the html coding is property of Sun Enterprise's and is copyrighted. Linking of this page is only permitted with written permission from myself to ensure sponsors and content of other pages are not obscene or illegal. Duplicating of this code is strictly prohibited and is an infringement of copyright laws.

Contents

● Important Safety Guidelines	
● Rules for safe marker handling	02
<h2><u>Operating Instructions</u></h2>	
● Charging	03
● Propellant gas supply	05
● Gassing up the Angel™	06
● Switching the Angel™ on	06
● Fitting the Viewloader™ VL2001 Intelifeed™	07
● Bolt removal Rotabrech	08
● Velocity adjustment	09
● Electronic rate of fire adjustment Sensatronics™	10
● General Care and Cleaning	11
<h2><u>Maintenance</u></h2>	
● Low Pressure regulator (LPR) adjustment	12
● Exhaust valve removal	13
● Ram Stroke adjustment	16
● Ram snap ring adjustment	17
● Mini reg on/off seal replacement	19
● Electronic valve dwell adjustment Sensatronics™	23
● Test pneumatics/electronics Sensatronics™	24
<h2><u>Parts List</u></h2>	
● Assembly drawing	20-21
● Accessories	25
● Figs 1- 11	26-35

- [Fault finding tables](#)
- [Warranties](#)
- [UK & Foreign Patents applied for](#)

Important Safety Guidelines

Rules for safe Marker handling

- Treat every marker as if it were loaded
 - Insert barrel bung when not in use
- Always remove gas source when not in use

NOTE: The Angel™ can hold a small gas charge, typically 2 shots. With the gas source removed, fire to remove this surplus gas.

- Ensure isolator switch is "off" when not in use.
 - Only use 0.68" calibre paintballs
 - Never use CO₂ as a propellant / gas source
- Never shoot at velocities in excess of 300 FPS / 91.44 MS
 - Always wear approved eye, face and ear protection.
- Only use the marker on fields approved for paintball games.

Operating Instructions

Charging

Before initial use of the Angel™, it is necessary to give the power pack a full charging cycle of 14 hours prior to use as this will ensure the longevity of the power pack. Subsequent charges will be in the region of 3 hours for full charge.

Stage 1

Insert cigar lighter into a 13.8v negative earth socket as found in most motor vehicles (red light on charger will illuminate).

Stage 2

Ensure isolator switch on the Angel™ is in the forward position towards the barrel. (No charging can occur until this switch is in the forward position).

Stage 3

Insert remote plug from charger into the socket on the rear of the Angel™.

Stage 4

The LED on the charger will indicate the status of the charging cycle on the Angel™.

1. NO LED power at cigar socket not present! Switch ignition on
2. DIM RED LED isolator switch on Angel™ is on Switch isolator off
3. BRIGHT RED LED FLASHING indicates battery conditioning from totally discharged battery
4. GREEN LED indicates trickle charging occurring, battery achieved 30% capacity

NOTE: The Angel™ may be left charging for prolonged periods without damage occurring to the battery pack.

Stage 5

Unplug the female socket from the Angel™.

PROPELLANT AIR/NITROGEN SUPPLY [\(SEE FIG.3\)](#)

- Ensure the Angel™ is switched off prior to commencing
- Ensure gas isolator green button "off" is fully depressed
 - Ensure barrel bung is fitted
 - Ensure eye protection is worn
 - Adhere strictly to all warnings
 - Ensure only air / nitrogen is used
- Ensure suitable regulator is used intended for a paintball marker

The Angel™ marker is designed to be operated on air or nitrogen only. This needs to be supplied to the Angel™ at a regulated pressure of 800 - 850 psi (55-59BAR). This can be achieved by the use of a suitable regulator such as the Govnair.

Connection can be made by connecting the regulator gas outlet to the Angel™ front grip using the connector supplied a suitable 1/8 BSP connector. If using the Mamba Micro Line™ as supplied, the fittings may be removed by pulling back the collet to release the hose then shorten the hose to the length required before refitting. Alternatively, the Mamba™ remote hose may be fitted into the collet.

GASSING UP THE Angel™ [\(SEE FIG.3\)](#)

Stage 1

Ensure the gas isolator green button "off" is pressed fully home.

Stage 2

Switch on your regulated gas supply

Stage 3

Press home the gas isolator red button "on".

NOTES: The gas isolator button must always be fully depressed. If pressed halfway, gass will be emitted around

the buttons which may be done to bleed your gas supply system prior to disconnection.

Warning: *The Angel™ will hold sufficient gas for 2 shots after isolation.*

Switching the Angel™ On [\(SEE FIG.2\)](#)

The electrical isolator/safety switch may now be switched "on" toward the rear of the marker. A green LED will illuminate on the rear of marker.

WARNING - *Adhere strictly to all safety warnings the Angel™ is now in an armed state.*

FITTING THE HOPPER VL2001 INTELIFFED™ OPTIONAL EXTRA PATENTS APPLIED FOR [\(SEE FIG.4\)](#)

The Angel™ has the ability to power the VL2001 Viewloader™ with the agitation and electrical supply coming from the Angel™ direct. This Intellifeed™ system monitors your fire rate and switches on the agitator as necessart. This hopper will feed 40% faster than a standard shredder hopper.

Stage 1

Fit eldow as supplied to the Angel™

Stage 2

Fit Viewloader VL2001 to the elbow as supplied

Stage 3

Plug the female socket into the rear of the Angel™ plug

Stage 4

Switch electrical isolator "on". The agitator will agitate for 2 seconds, then stop.

NOTE: *On single shots less than 1 shot per second, the VL2001 will not agitate. On shots greater than 2 shots per sencond, the VL2001 will agitate for 2 seconds. This cycle will repeat as the trigger is pulled.*

BOLT REMOVAL ROTABREECH™ PATENTS APPLIED FOR [\(SEE FIG.5\)](#)

Stage 1

Ensure the elctrical isolator switch is off. The LED on the rear of the Angel™ will not be illuminated

Stage 2

Pull the "pull knob" and rotate 90 degrees so that the knob remains in the unlocked position

Stage 3

Swing the breech block so that the bolt is exposed

Stage 4

Retract the bolt

Stage 5

Replace the bolt follow stages in reverse order

NOTES: *Caution, do not fire the Angel™ with the breech open or without the bolt in the breech. Caution, do not fire the Angel™ with the pull knob in the unlocked position. The breech will not open if the bolt is in the forward position, ensure it is retracted by either:*

- 1. momentarily gassing the Angel™*
- or*
- 2. pushing the bolt back with a squeegee*

Velocity adjustment [\(See fig.3\)](#)

Velocity adjustment need to be carried out using a suitable chronograph, the maximum velocity to be set is 300 FPS.

The velocity adjusting screw is located on the front grip. Use a 3 mm A/F allen key to adjust.

Stage 1 - Decrease Velocity

To Decrease velocity, insert the allen key and rotate CLOCKWISE.

Note: *when reducing velocity, allow 4 shots for the complete system to be at the new regulated pressure*

To Increase Velocity

To Increase velocity, insert the allen key and rotate ANTI-CLOCKWISE

ELECTRONICS RATE OF FIRE ADJUSTMENT SENSATRONICS™ PATENTS APPLIED FOR [\(SEE FIG.6\)](#)

The Angel™s rate of fire is adjustable so that it may be set up to suit your style of play. It is factory set at approximately 10-12 shots per second.

Stage 1

Remove grip cover screws to expose circuit board.

Stage 2 - Decrease rate of fire

Rotate the top out on the circuit board anticlockwise to reduce the rate of fire. Minimum setting achievable is 6 shots per second.

Stage 3 - Increase rate of fire

Rotate the top out on the circuit board clockwise to increase the rate of fire, maximum achievable is 15 shots per second. (The best results are achieved when using the Viewloader™ VL2001 Intelifeed™)

***NOTE:** If you set the rate of fire in excess of what the hopper can feed, you will experience ball chopping, therefore it is advisable to ensure that you adjust the pot in small movements.*

GENERAL CARE & CLEANING

The Angel™ should be cleaned using a damp cloth only.

No solvents or abrasive cleaning products should be used. All external moving parts should be lubricated using a light oil. The Angel™ should never be immersed into water, otherwise damage may occur to the electronics. The electronics are moisture/damp proof only. Ensure correct tools are used. All thread are metric except gun accessory mounting onto the grip frame which is industry standard 10/32 UNF at centres 3/4".

MAINTENANCE

LOW PRESSURE REGULATOR (LPR) ADJUSTMENT [\(SEE FIG.7\)](#)

The low pressure regulator controls the pneumatics cycle of the Angel™ and is located in the left hand chamber in the front of the Angel™'s body. The pressure needs to be at 80-90psi (55 - 60 BAR) and adjustment is achieved by the addition or removal of shims, each shim equals approximately 2.5 psi (0.17 BAR).

Stage 1

Ensure the Angel™ is degassed and the isolator switch is "off".

Stage 2

Remove the end cap

***NOTE:** This end is a different design to the battery end cap.*

Stage 3

Insert M3 screw into the brass piston and withdraw slowly.

CAUTION: ensure the springs or shims are not lost.

Stage 4

Insert/remove shims as necessary each shim equals approximately 2.5 psi (0.17 BAR).

Stage 5

Replace springs in correct order onto the piston

Stage 6

Re-insert the piston ensuring that it is located correctly and replace end-cap

Stage 7

Gas up the Angel™ and check pressure

EXHAUST VALVE REMOVAL ([SEE FIG.8](#))

Stage 1

Remove high pressure regulated gas supply

Stage 2

Remove component in number order as per [figure 7](#) Item 1 - Unscrew mini reg

Item 2 - Use metric allen key to remove screw

Item 3 - Slide flash tank forward

Item 4 - Remove O ring

Item 5 - Pull pin out

Item 6,7,8,9 - Remove as per low pressure regulator (LPR) adjustment instructions.

Item 10 - Using a suitable pick, slowly retract LPR. Care must be taken so that the bore or seals are not damaged.

Item 11 - Remove valve spring

Item 12 - Remove exhaust valve.

Stage 3

Re-assembly of components - important notes

Item 12 - Ensure exhaust valve is located in exhaust body within the Angel™

Item 11 - Ensure the spring is located on to item 12

Item 10 - Ensure the hole for item 5 is in the correct orientation prior to refitting

Item 8 - Ensure the springs are in the right order

Item 5 - Ensure the pin locates into the hole in itme 10

Item 5 - Ensure O ring is present when item 3 is replaced.

RAM STROKE ADJUSTMENT PATENTS APPLIED FOR [\(SEE FIG.9\)](#)

Stage 1 (see [figs 2](#) and [fig 3](#))

Ensure the gas supply is isolated
Ensure the electrical isolator switch is off
Ensure bolt is fully retracted

Stage 2

Remove components 1-5

Item 1 - Remove by gently pulling and unscrewing anit-clockwise

Item 2 - Remove screws using suitable metric allen key.

Item 3 - Carefully lift item 3 as wires are attached. Care must be taken so that they are not pulled or trapped during maintenance.

Item 4/5 - Retract lock pin and spring.

Stage 3

Using circlip pliers rotate ram/hammer item 6 clockwise until slight resistance is felt in opening the breech / bolt. If rotated too far the breech will not open so rotate anti-clockwise and repeat operation. Note the ram is always set by rotating item 6 clockwise.

Stage 4

Replace components in order 5-1

Ensure that no wires become trapped

Ensure that item 1 is screwed on so that when the pullknob is in the open position, the breech can open.

RAM SNAP RING ADJUSTMENT/REPLACEMENT PATENTS APPLIED FOR [\(SEE FIG.9\)](#)

Stage 1

Follow ram stroke adjustment procedure for disassembly and access.

Stage 2

Item 7 - Remove snap ring nut using suitable metric allen key. Ensure that item 6 does not move by holding in place with circlip pliers.

Item 8 - Remove with suitable pick, replace if worn or damaged.

Stage 3

Replace item 5, locking the breech/bolt in place.

Stage 4

Replace item 7 ensuring the ram/hammer assembly item 6 does not rotate (secure using circlip pliers) until slight resistance is felt.

Stage 5

Gas up the Angel™ and switch the electrical isolator switch on (fig. 2/3)

Stage 6

WARNING! - Adhere strictly to all safety instructions

Fire the Angel™ while rotating item 7 clockwise until the Angel™ ceases to fire, now rotate item 7 anticlockwise 1/4 of a turn and check the Angel™ to ensure it fires.

Stage 7

Replace the remaining parts as per ram stroke adjustment.

NOTE: Ensure no wire becomes trapped.

MINI REG ON/OFF SEAL REPLACEMENT [\(SEE FIG.10\)](#)

Stage 1

Ensure the gas supply is isolated at its source.

Stage 2

Unscrew item 1 from item 2 and retract the parts.

Stage 3

Replace any worn seals on items 3 and 4.

Note:

Item 3 is a hard seal

Item 4 is a soft seal

Stage 4

Replace items 4-1

Stage 5

Re-gas system, check for leaks.

[Picture of Dissassembled Angel™](#)

Part No.	Parts Description	Quant Per Assem	Part No.	Parts Description	Quant Per Assem
AL008	Grip Frame Anodized	1	AL088	Exhaust Body Seal (REAR)	1
AL009	Grip Frame Seal	1	AL089	Exhaust Body Seal (FRONT)	1
AL021	Mini Reg Velocity Adj Screw	1	AL090	Exhaust Valve Spring	1
AL024	Mini Reg Dump Seal Front 70 S	1	AL092	Back Plate Fixing Screws	2
AL025	Mini Reg Seal Rear 90 S	1	AL094	LED Lens	1
AL026	Mini Reg Adjust Piston	1	AL097	Wiring Loom	1
AL027	Mini Reg Adjust Piston Seal	1	AL098	Circuit Board	1
AL028	Mini Reg Piston	1	AL099	Charger	1
AL029	Mini Reg Large Piston Seal	1	AL100	Circuit Board Fixing Screw	1
AL030	Mini Reg Spring Stack	10	AL101	Isolator Switch Fixing Screw	2
AL033	Mini Reg to Flash Tank Seal	1	AL016	Grip Frame Fixing Screws	2
AL034	Mini Reg Ball Bearing	1	AL108	14 Way Valve Cover	1
AL035	Mini Reg Circlip	1	AL109	Trigger Spring	1
AL037	Flash Tank Feed Pipe Anodized	1	AL110	Trigger Tensioning Screw	1
AL038	Flash Tank Feed Pipe Seal	1	AL111	14 Way Seals	4
AL039	Flash Tank Seal	1	AL112	14 Way Body Anodized	1
AL040	Flash Tank Fixing Screw	1	AL113	14 Way Piston	1
AL043	LPR Chamber Plug Seal	1	AL114	14 Way Safety Vent Body	1
AL045	LPR Piston	1	AL115	14 Way Safety Vent Piston	1
AL046	LPR Piston Seal	1	AL116	14 Way Safety Vent Nut	1
AL047	LPR Spring Stack	1	AL117	14 Way Safety Vent Spring	1
AL052	LPR Shims	variable	AL118	14 Way Safety Vent Ball Seal	1
AL054	LPR External Seals	2	AL129	Anti-Double Ball Seal	1
AL057	Battery Chamber Plug	1	AL145	Battery Cap Anodized	1
AL058	Battery Bumper	2	AL146	LPR Chamber Plug Anodized	1
AL059	Battery Pack	1	AL147	Feed Tube Anodized	1

AL060 Hammer	1	AL148 Anti Double Ball Anodized	1
AL061 Ram Body Seals	3	AL149 LPR Body Anodized	1
AL070 Ram Snap Ring 90 Shore	1	AL150 LPR Adjuster Anodized	1
AL071 Ram Snap Ring Screw	1	AL151 RAM Cap Anodized	1
AL073 Breech Blok Pivot Screws 4BA	2	AL152 RAM Cap Anodized	1
AL074 Breech Blok Seal 70 Shore	1	AL153 RAM Body Anodized	1
AL075 Breech Blok Pivot Pin (FRONT)	1	AL154 Mini-Reg On Pin Anodized	1
AL076 Breech Blok Pivot Pin (REAR)	1	AL155 Mini-Reg Off Pin Anodized	1
AL077 Breech Blok Lock Pin	1	AL156 Trigger Anodized	1
AL078 Breech Blok Lock Pin Spring	1	AL157 Flash Tank Anodized	1
AL079 Breech Blok Release Knob	1	AL159 Barrel Anodized	1
AL082 Bolt	1	AL160 Back Plate Anodized	1
AL084 Exhaust Valve	1	AL164 Breech Blok Anodized	1
AL086 Exhaust Main Body	1	AL165 Mini-Reg Anodized	1
AL087 Exhaust Body Lock Pin	1		

ELECTRONIC VALVE DWELL ADJUSTMENT SENSATRONICS™ PATENTS APPLIED FOR [\(SEE FIG.6\)](#)

Stage 1

Remove grip, cover screws to expose circuit board.

Stage 2

Rotate valve dwell pot fully anti clockwise

Stage 3

Set velocity at 300FPS [\(see fig.6\)](#)

Stage 4

Rotate valve dwell pot clockwise until velocity starts to fall.

Stage 5

Re-assemble.

TESTING PNEUMATICS/ELECTONICS SENSATRONICS™ PATENTS APPLIED FOR [\(SEE FIG.11\)](#)

The design of the Angels™ can be divided into 2 elements, which enable you to evaluate where a problem may have occurred. To evaluate the pneumatics follow the procedure listed.

Stage 1

Ensure the Angel™ is switched 'on' and gassed up.

Stage 2

Remove the 2 fixing screws item 1 using suitable metric allen key.

Stage 3

Gently lift off the cover plate item 2 and ensure the wires do not become snagged.

Stage 4

Using a sharp pencil press and hold the orange button item 4. The pneumatics will now operate as all the electronics are bypassed.

Stage 5

On removing the pencil the pneumatics will reset. This shows that pneumatics have functioned correctly.

Stage 6

Ensure the green LED is illuminated at the rear panel point 2.

***NOTE:** If gas is emitted from Item 3, this indicates excessive pressure is present. Do not adjust Item 4 as this is a factory set safety valve see LPR pressure adjustment.*

Stage 7

Pull the trigger and a red LED item 5 will illuminate momentarily indicating the electronics are functioning correctly.

ACCESSORIES - FULL AUTO MODE SENSATRONICS™ PATENTS APPLIED FOR

The Angel™ is a semi auto paintball marker that may be converted to a full auto paintball marker by replacing the circuit board. This conversion is not switchable by any means other than replacing the circuit board.

***WARNING-** THIS ACCESSORY WILL ONLY BE SUPPLIED TO COUNTRIES WHERE A FULL AUTO PAINTBALL MARKER IS PERMITTED BY LAW. ALWAYS OBSERVE ALL LOCAL APPLICABLE LAWS REGULATING AIR POWERED GUNS.*

VIEWLOADER™ VL2001 INTILIFEED™ PANTENTS APPLIED FOR

The Angel™ has the ability to power and control the VL2001 which will greatly enhance the performance of the Angel™ with a 40% increase in feed rate over existing standard hoppers.

Figures 1 - 11

[FIGURE 1](#)

[FIGURE 2](#)

[FIGURE 3](#)

[FIGURE 4](#)

[FIGURE 5](#)

[FIGURE 6 & 7](#)

[FIGURE 8](#)

[FIGURE 9](#)

[FIGURE 10](#)

[FIGURE 11](#)

FAULT FINDING

Angel™ WILL NOT FIRE	SEE GASSING UP THE Angel™
IS AIR/NITROGEN PRESENT?	SEE GASSING UP THE Angel™
IS BATTERY PACK CHARGED?	SEE CHARGING
IS GAS ON/OFF PIN IN "ON" POSITION?	SEE GASSING UP THE Angel™
IS ELECTRICAL ISOLATOR SWITCH "ON"?	SEE SWITCHING THE Angel™ ON
IS BOLT JAMMED?	UNJAM BOLT
IS RAM SNAP RING TOO TIGHT?	SEE RAM SNAP RING ADJUSTMENT
IS PNEUMATICS WORKING?	SEE TESTING PNEUMATICS/ELECTRONICS
IS CIRCUIT BOARD WORKING?	SEE TESTING PNEUMATICS/ELECTRONICS

VELOCITY TOO LOW/HIGH?	
IS INLET FROM HIGH PRESSURE REGULATOR SET CORRECTLY?	SEE PROPELLANT GAS SUPPLY
IS VELOCITY ADJUSTER SCREW SET CORECTLY?	SEE VELOCITY ADJUSTMENT
IS BOLT STICKING?	CHECK MOVEMENT
IS LPR SET CORRECTLY?	SEE LPR ADJUSTMENT
IS VALVE DWELL SET CORRECTLY?	SEE ELECTRONIC VALVE DWELL ADJUSTMENT
IS RAM SET CORRECTLY?	SEE RAM STROKE ADJUSTMENT
IS SNAP RING SET CORRECTLY?	SEE RAM SNAP RING ADJUSTMENT
CHOPPING BALLS	
IS SUITABLE WORKING HOPPER FITTED?	SEE ACCESSORIES
IS RATE OF FIRE SET CORRECTLY?	SEE RATE OF FIRE ADJUSTMENT
FIRING TOO SLOW	
IS RATE OF FIRS SET CORRECTLY?	SEE RATE OF FIRE ADJUSTMENT
EXCESS NOISE/GAS CONSUMPTION	
IS VALVE DWELL SET CORRECTLY?	EE ELCTRONIC VALVE DWELL ADJUSTMENT
IS LPR PRESSURE SET CORRECTLY?	SEE LPR ADJUSTMENT
IS EXHAUST VALVE FAULTY?	SEE EXHAUST VALVE REMOVAL/REPLACEMENT
IS GAS LEAKING?	
MIN REG ON/OFF	SEE MINI REG SEAL REPLACEMENT
FROM BACK COVER	SEE TESTING PNEUMATICS/ELECTRONICS
FROM GAS JOINTS	CHECK ALL FITTINGS
FROM EXHAUST VALVE	SEE EXHAUST VALVE REMOVAL/REPLACEMENT
FROM RAM	SEE TESTING PNEUMATICS/ELECTRONICS
FROM TOP OF FRONT GRIP	IS "O" RING PRESENT, SEE LPR

TERMS OF WARRANTY

- Subject to the conditions set out below the company warrants that the Angel™ will correspond to its specification at the time of delivery and will be free from defects in materials and workmanship for a period of six months from date of purchase.
 - The above warranty is given by the company subject to the following conditions:
 - Proof of purchase is required in all warranty claims;
 - Warranty is not transferrable.
 - The company shall be under no liability in respect of any defect arising from fair wear and tear.
- Seals, batteries, wiring, indicator lamps and exhaust valves are not covered by this warranty. Willful damage,

negligence, abnormal working conditions, weather, accident, tampering, failure to follow the manufactures instructions (whether oral or in writing), misuse or alteration or repair of the Angel™ without the company's written approval will invalidate this warranty and the company shall be under no obligation whatsoever to the purchaser in respect of any of the above breaches of this warranty.

- The above warranty does not extend to parts, materials or equipment not manufactured by the company, in respect of which the purchaser shall only be entitled to the benefit of any such warranty or guarantee as is given by the manufacturer to the company.
- Subject as expressly provided in these conditions, and except where the goods are sold to a person dealing as a consumer (within the meaning of the Unfair Contract Terms Act 1977) all warranties, conditions or other terms implied by statute or common law are excluded to the fullest extent permitted by law.
 - Where the goods are sold under a consumer transaction (as defined by the Unfair Terms in Consumer Contracts Regulations 1994 S13159) the statutory rights of the purchaser are not affected by these conditions.
 - Where any valid claim in respect of the Angel™ is based in the quality or condition of the Angel™, or its failure to meet specification, and such valid claim is notified to the company in writing and is in accordance with the company's standard terms and conditions of sale the company shall be entitled to repair or replace the goods or the part in question free of charge or, at the company's sole discretion, refund to the purchaser the price of the goods (or a proportionate part of the price) but the company shall have no further liability to the purchaser.
 - Except in respect of death or personal injury caused by the company's negligence, the company SHALL NOT be liable to the purchaser by reason of any representation, or any implied warranty, condition or other term, or any duty at common law, or under the express terms of this guarantee, for any direct or indirect, special or consequential loss or damage whether to persons or property, costs, expenses, or other claims for compensation or damages whatsoever (whether caused by the negligence of the company, it's employees or agents or otherwise) which arise out of or in connection with the supply of the Angel™, it's use, or misuse, or resale by the purchaser, or any individual, and the entire liability of the company under or in connection with the purchase or the misuse of the Angel™ shall not exceed the purchase price of the Angel™.
 - **Puchaser agrees to adhere strictly to all warnings and safety procedures.**
 - This warrenty shall be governed by the laws of England and the purchaser agrees to submit to the non exclusive jurisdiction of the English courts.

The supply and the purchase of the Angel™ is subject to the company's standard terms and conditions of sale, a copy of which is available upon request. Angel™-patent applied for, design rights and all rights reserved. The Angel™ is marketed and distributed by WDP Ltd. A company registered in England

No.2114341

Tel: +44 121 328 2228 Fax: +44 212 327 3967

Issue No.1 Angel™ Users Guide.

FIGURE 1

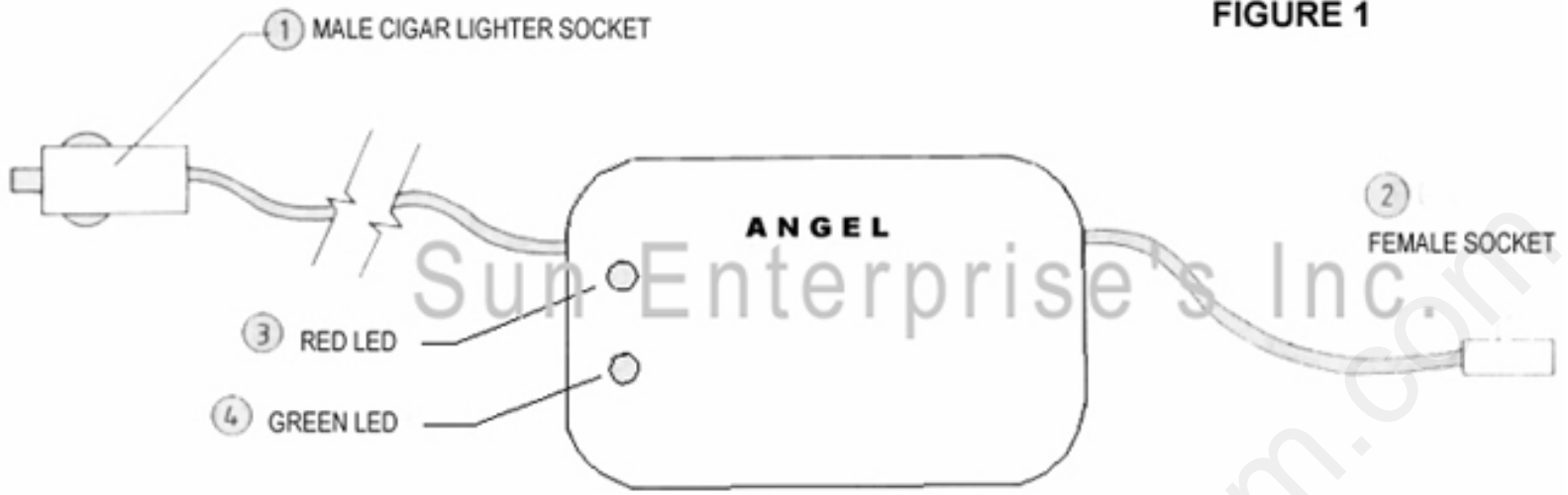
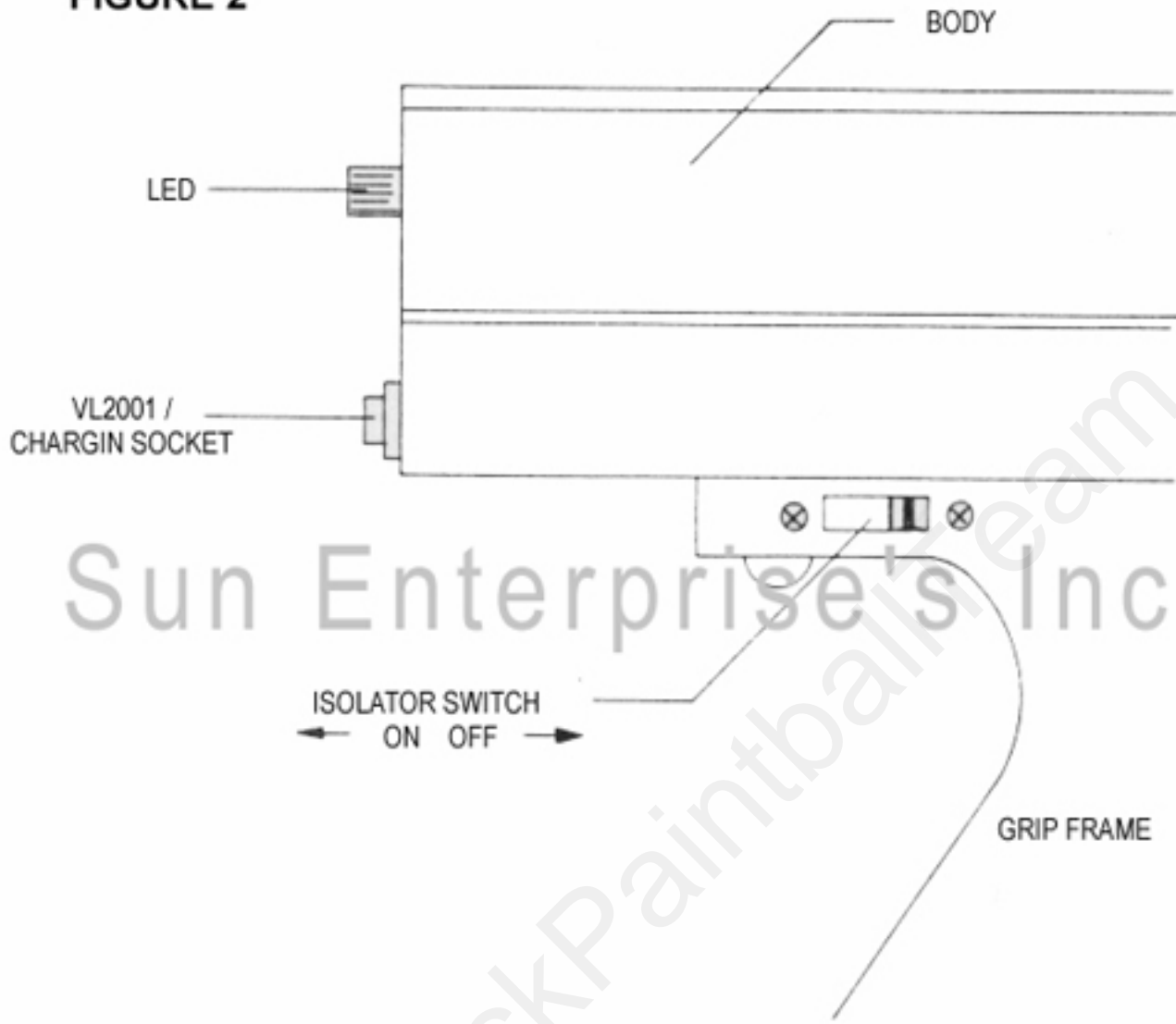

FIGURE 2



Sun Enterprises's Inc.

FIGURE 3

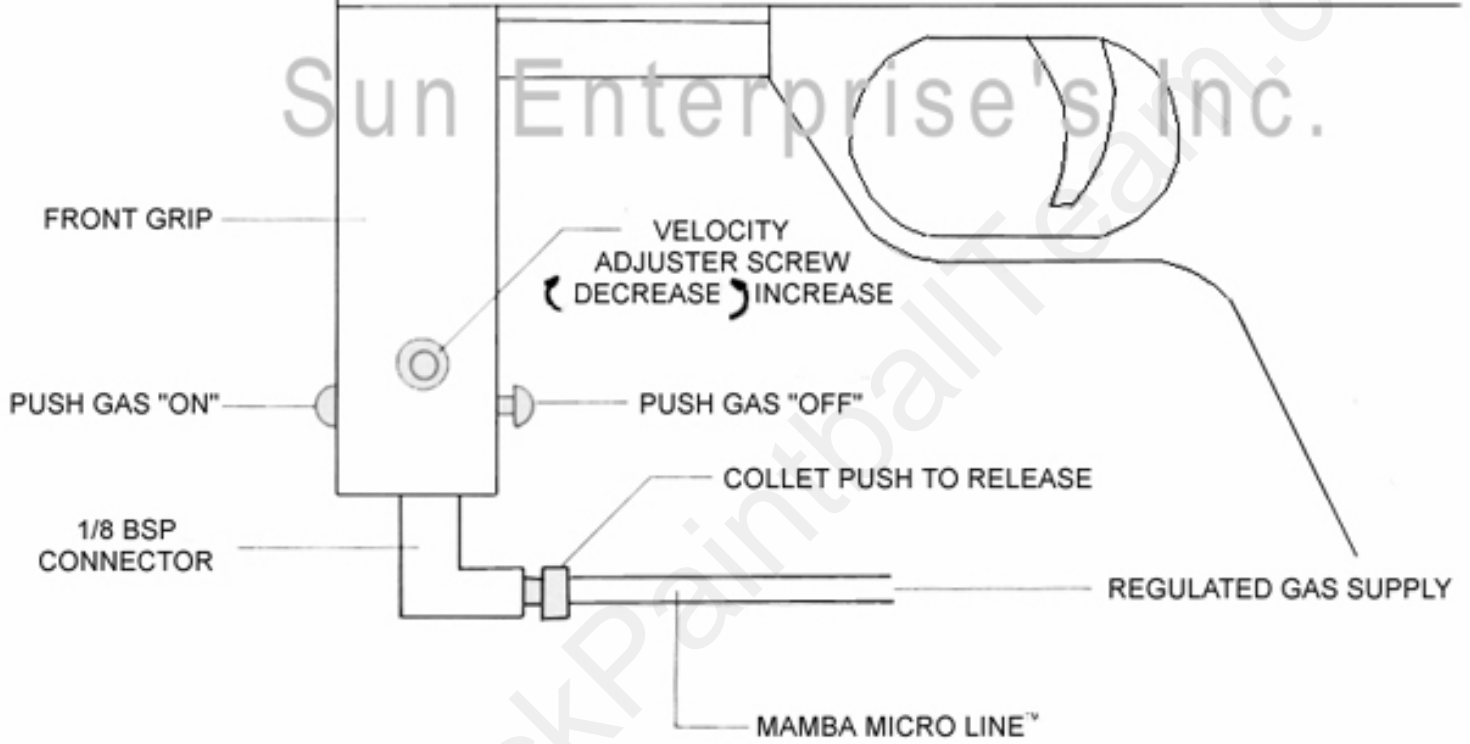
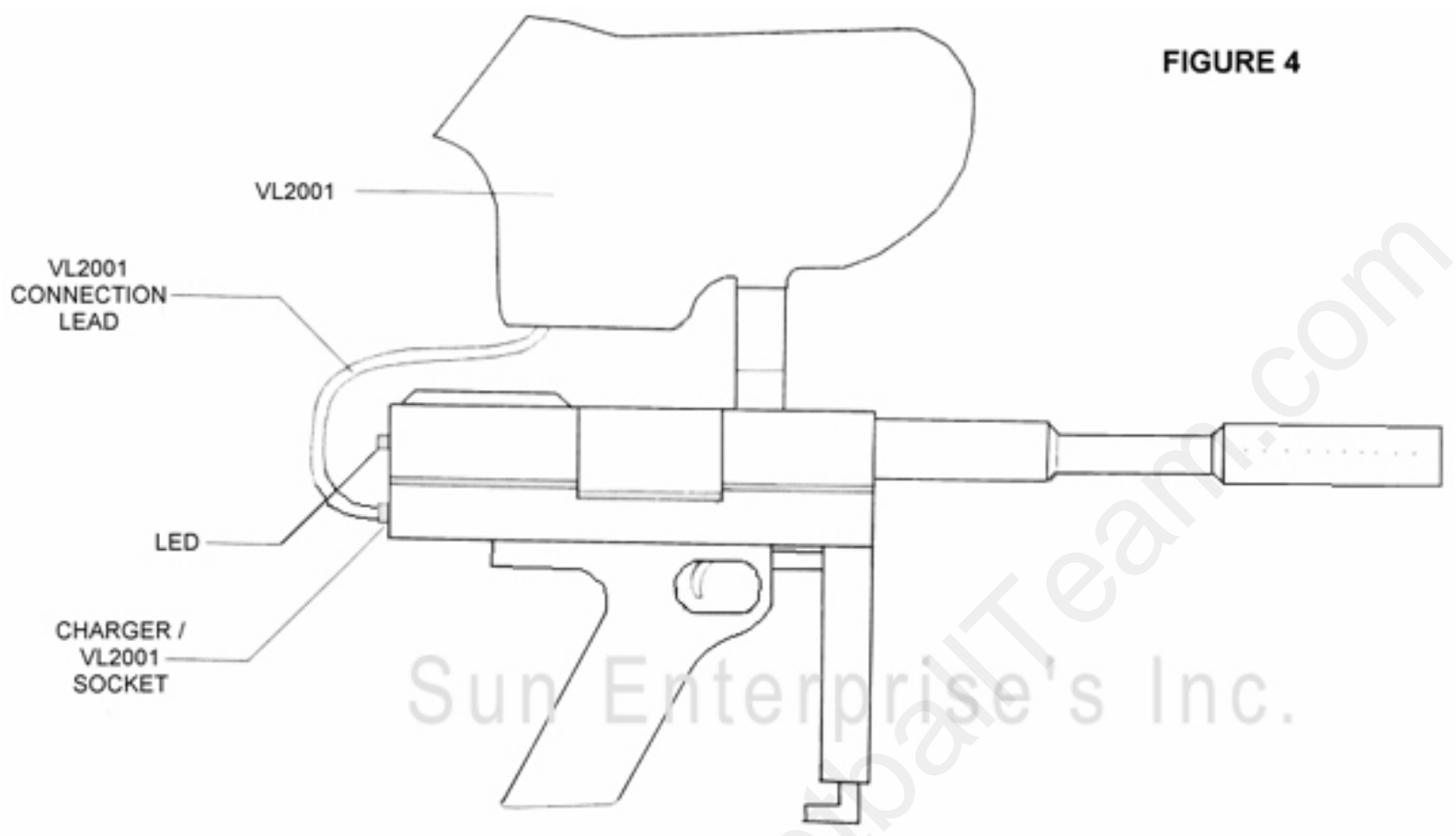
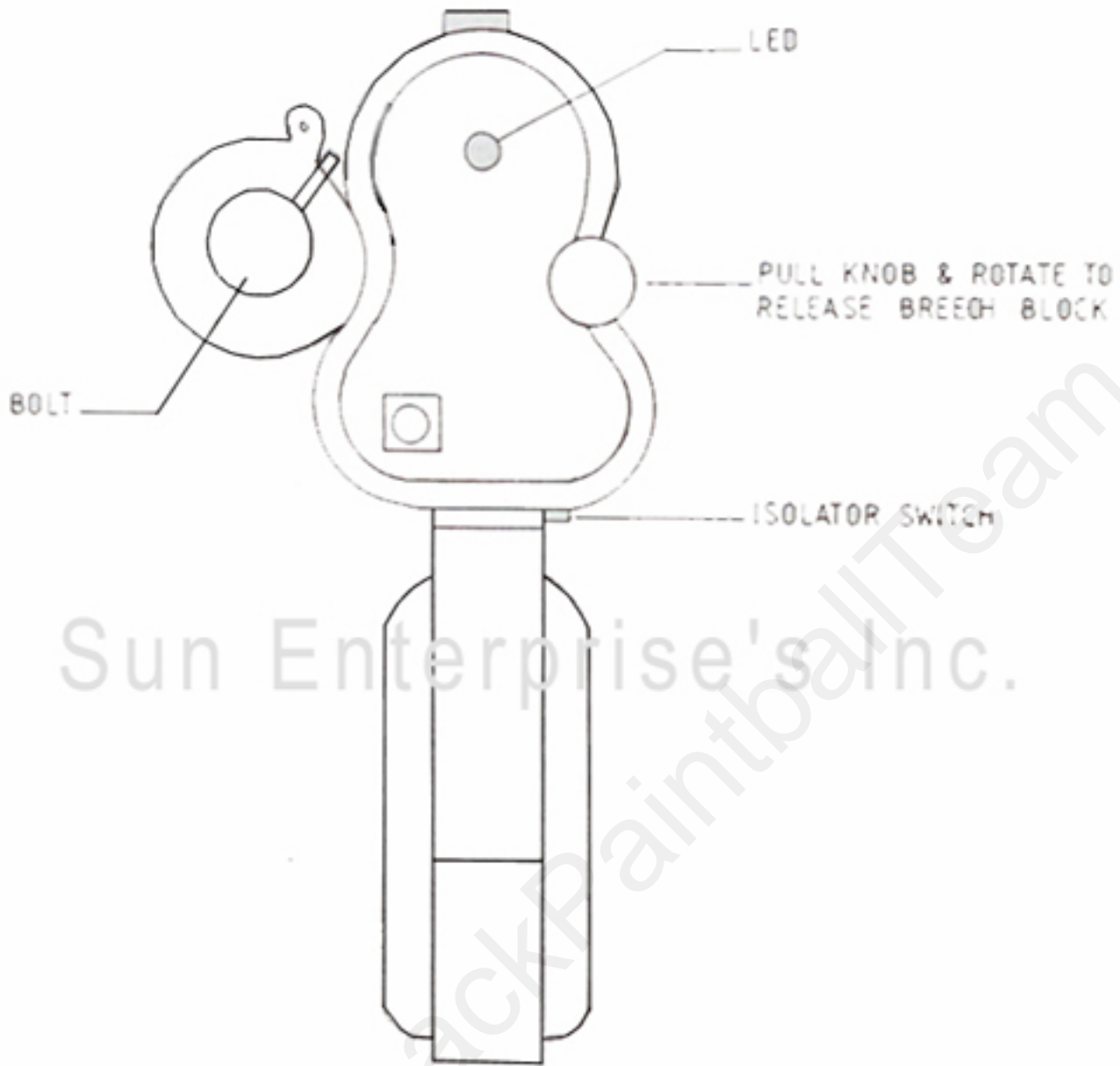
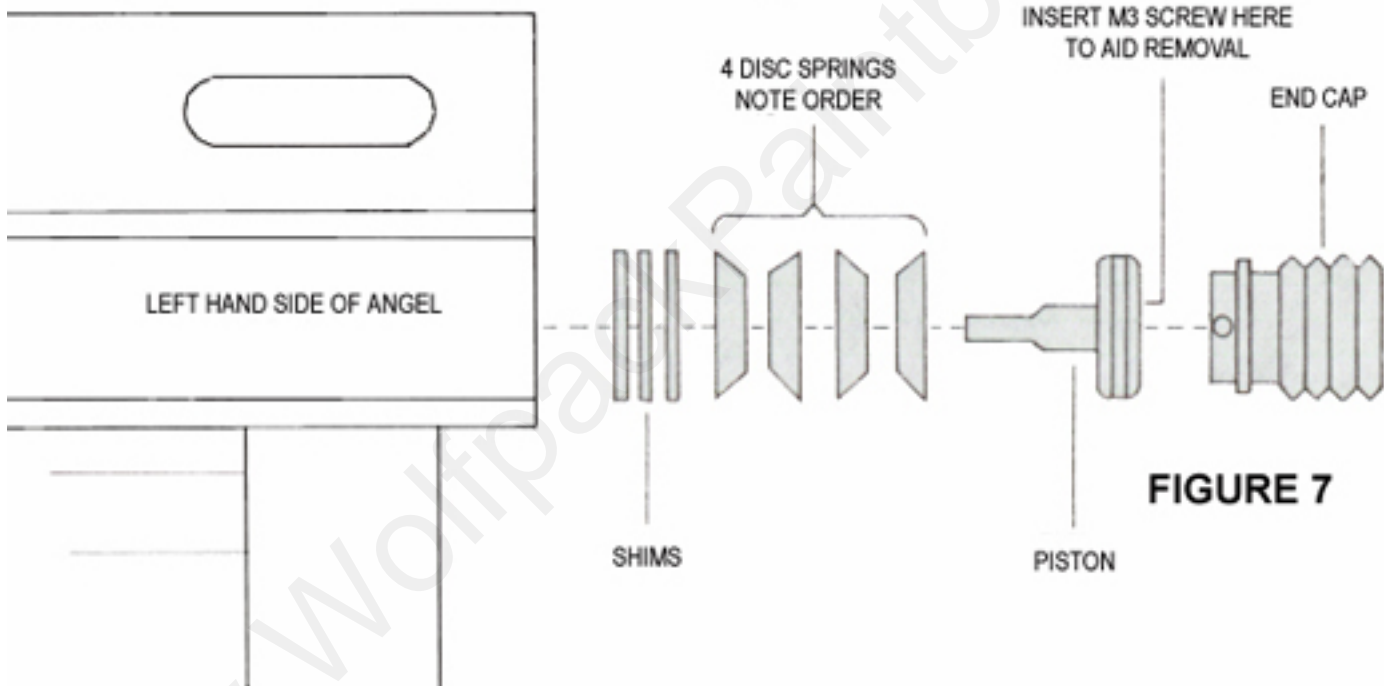
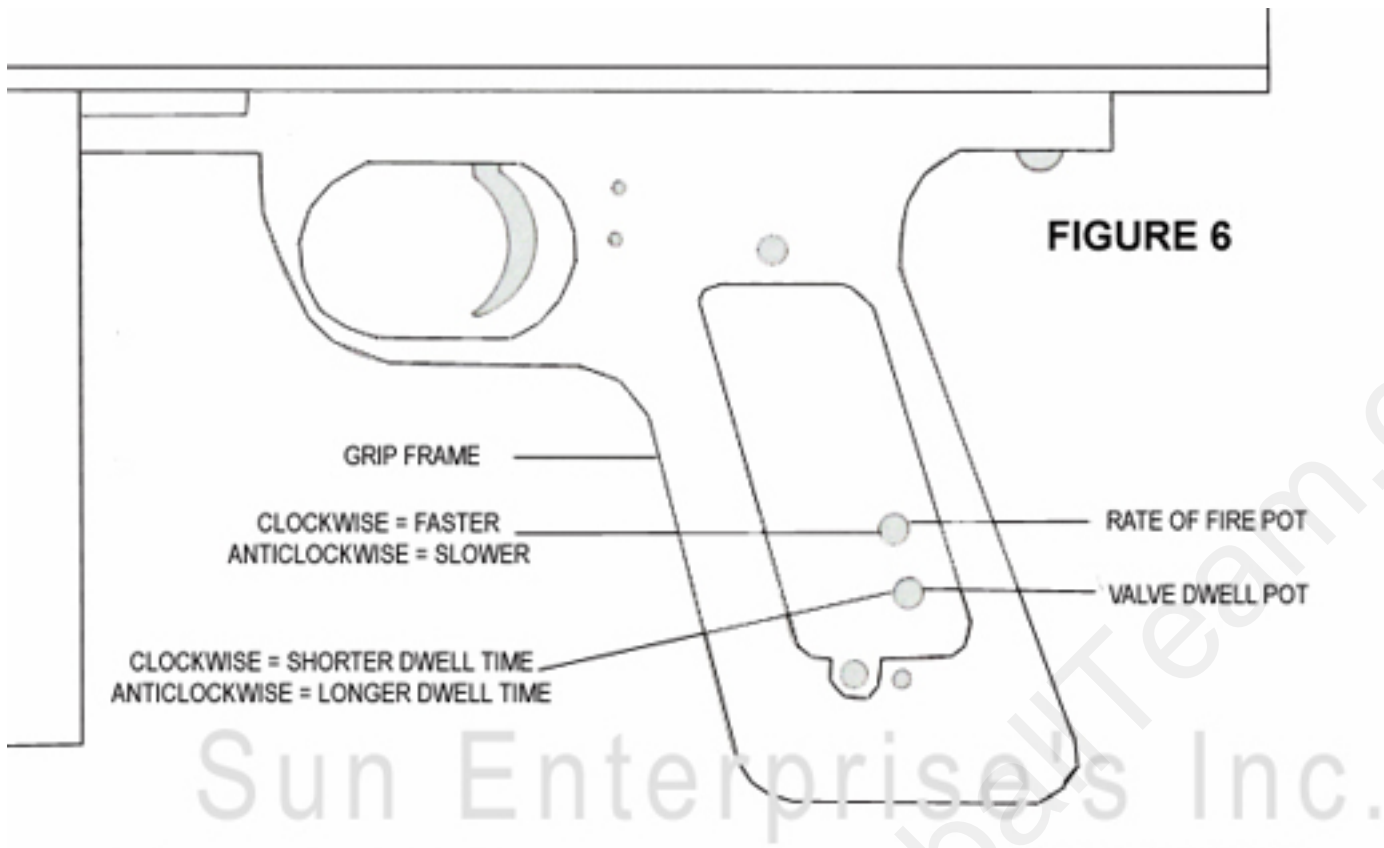

FIGURE 4





Sun Enterprise's Inc.



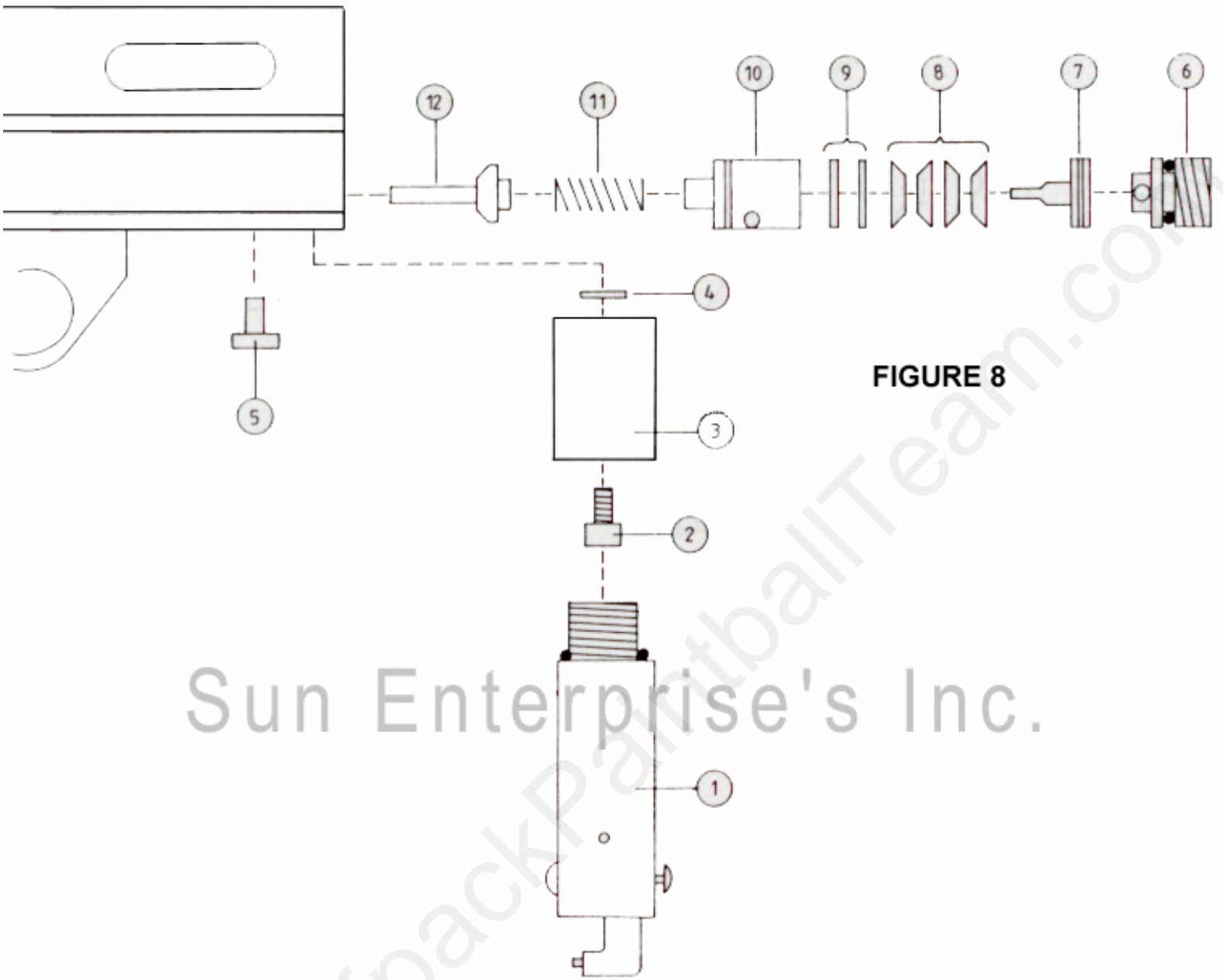

FIGURE 8

Sun Enterprise's Inc.

FIGURE 9

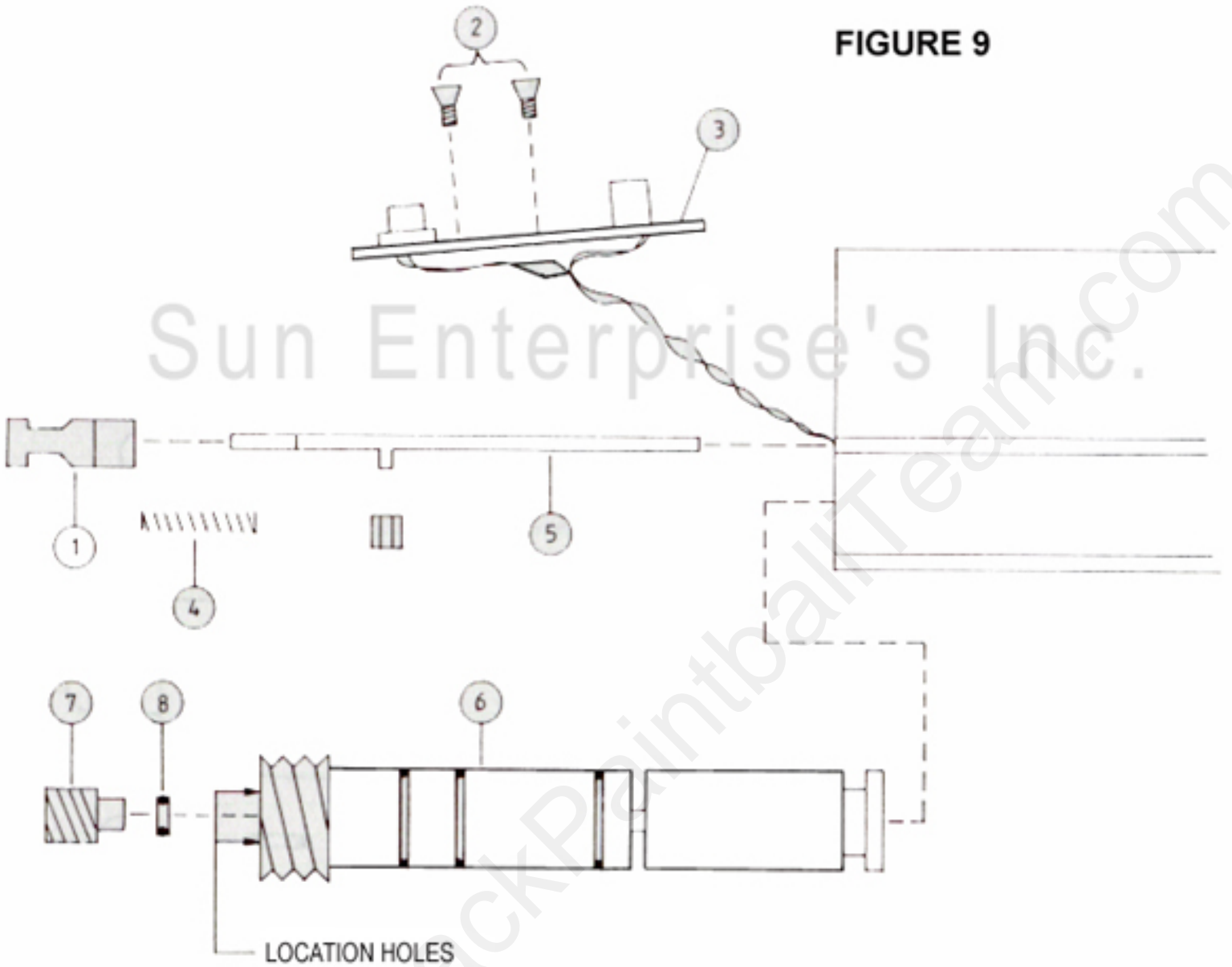
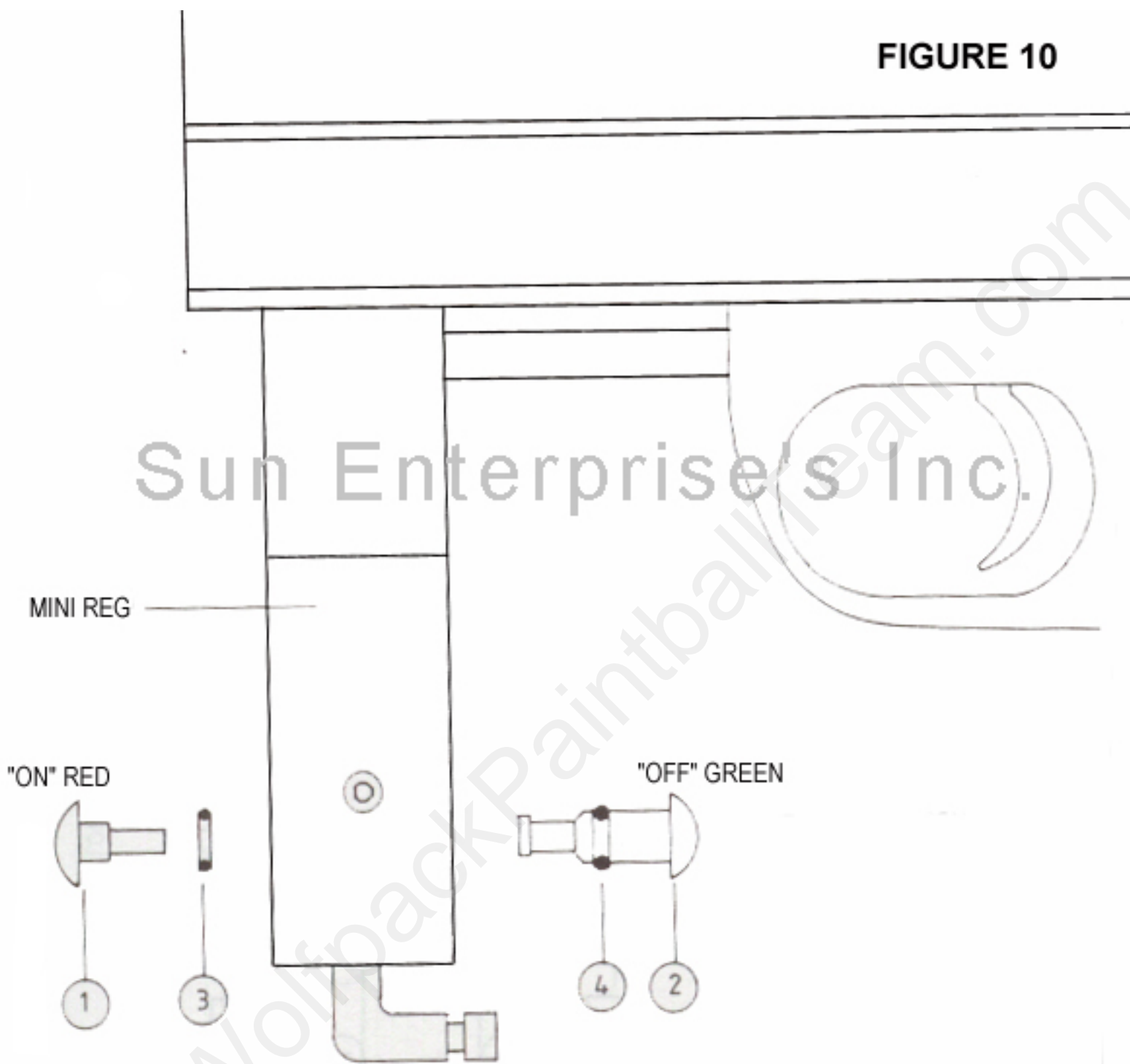
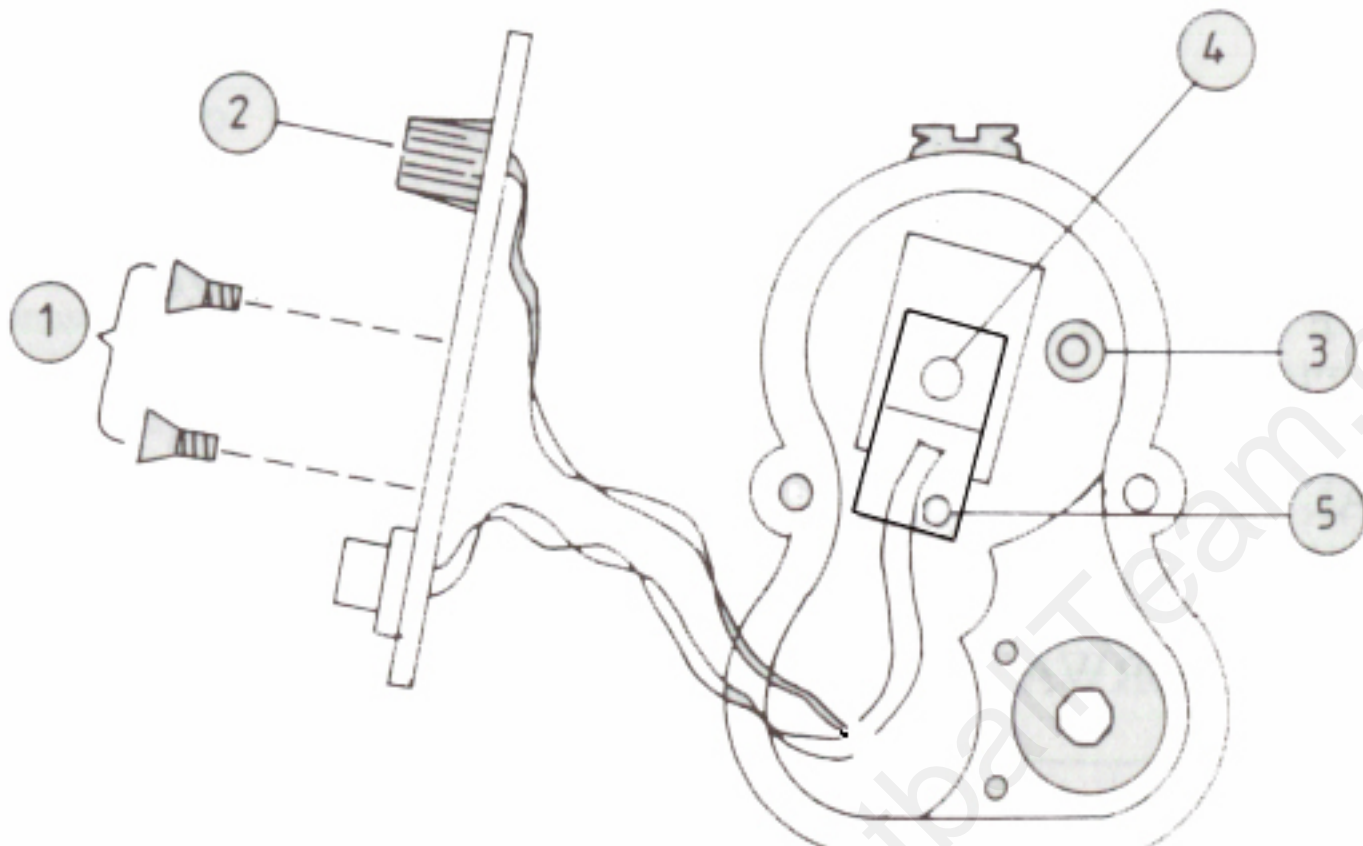

FIGURE 10





Sun Enterprise's Inc.

FIGURE 11