

!WARNING!

IMPORTANT SAFETY INSTRUCTION AND GUIDELINES

- This Paintball Marker is NOT A TOY. Misuse can cause serious injury or death.
- Recommend 18 years or older to purchase this product. Person under 18 must have adult supervision.
- Read this manual, understand and follow the manual instructions for using this product.
- Eye and face protection specially designed for paintball use, must be worn by user and persons within range at all times.
- Treat all paintball markers as if it were loaded and able to fire.
- Never look down the barrel or breech area of a marker.
- Always use barrel blocking device when the marker is not in use.
- Always chronograph this marker before playing paintball.
- Never shoot any marker at velocities exceeds 300 FPS (Feet Per Second), or velocities which is greater than local fields or national laws allow.
- Ensure all air lines and fittings are tightened and secured before installing the air tanks.
- Do not shoot at people, animals, houses, cars or anything is not related to the sport of paintball.
- Always keep the marker in Safe mode until ready for use.
- Fire only 0.68 caliber paintballs with this marker.
- Always make sure the bolt is in the un-cocked position when marker is not in use.
- Any modifications or tampering of original factory parts will cause all warranties and liabilities from Azodin Paintball.
- This owner's manual should always accompany this marker for reference and in the event of resale and new ownership.

!WARNING!

IMPORTANT CO2/ HPA AIR TANK SAFETY INSTRUCTION AND GUIDELINES

- Tank valves must be installed or removed by qualified personnel.
- All tanks must be retested before the expiration date.
- Improper use, filling, storage of this air tank may cause death, serious injury and property damage.
- Air tanks must be filled only by properly trained personnel.
- Do not over pressurize. Do not expose pressurized tanks to temperatures in excess of 130F° degrees (54°C).
- Do not expose tanks to corrosive materials and do not clean with caustic cleaners.
- Do not alter tanks in any way.
- Tanks heated up to a temperature of 250F° degrees (54°C) or more must be condemned or re-qualified.
- Keep air tanks out of reach of children.
- The valve should NEVER detach from the tank canister. Should this occur, seek assistance from a qualified airsmith immediately.
- Air tanks are use for the sport of paintball only.

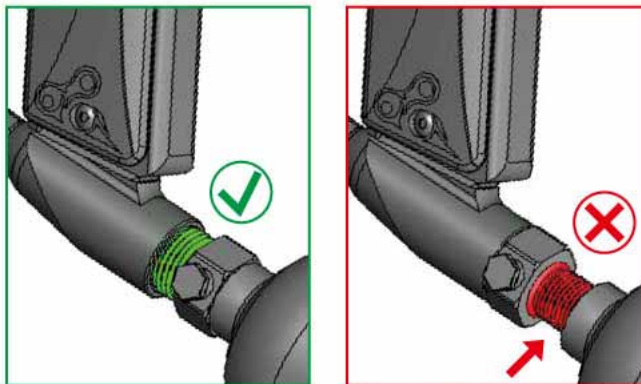

CO2 or HPA/ N2 Air tanks will have enough force to fly off and cause serious injury or death if the valve unscrews from the tank head.

Look at the valve when removing the tank from the marker's Bottom ASA (A021). Make sure that the valve is turning with the tank instead of staying with the marker.

STOP IMMEDIATELY if valve starts to unscrew from the tank itself. Screw the tank back onto the marker's Bottom ASA adapter and contact a qualified airsmith for further assistance.

GETTING STARTED

1. First, place the BARREL BLOCKING DEVICE over the barrel.
2. Always point your marker at a "SAFE" direction before use. To use, push the safety button from the "PUSH SAFE" side of the grip frame. Doing this will put the marker in a lock safe mode. To unlock the safe mode, point the marker in the safe direction, and push the safety button towards the "PUSH SAFE" side of the grip frame.
3. Firmly screw in the CO2/ HPA/ N2 air tank to the Bottom ASA (A021). Tighten the air tank clockwise all the way in the marker's bottom ASA.
CAUTION: Never use any hand tool to screw air tank to the bottom ASA.
4. Attach a paintball hopper/ loader to the marker's feed neck.
5. Remove the barrel blocking device and unlock the safe mode.
CAUTION: Now the marker is LIVE, pulling the trigger will fire a paintball. Only test your marker at the safe direction or in a proper organized paintball field.
6. Check marker's velocity FPS (Feet Per Second). Turning the velocity adjuster (P023) clockwise will increase the velocity. Counterclockwise will decrease the velocity.
7. After playing, take out all paintballs from the hopper. Then detach the hopper from the marker.
CAUTION: There may be 1-2 paintballs in the breach area; take a couple more shots in a safe direction to make sure the marker is empty of paintballs.
8. Place the barrel blocking device over the barrel and push the safety button in the safe mode.
9. Unscrew the CO2/ HPA/ N2 air tanks from the marker's bottom ASA.
CAUTION: Never use any hand tool to screw air tanks to the bottom ASA.
10. Store the marker in a paintball gear bag or in a safe place.

VELOCITY ADJUSTMENTS

(INCREASE & DECREASE)

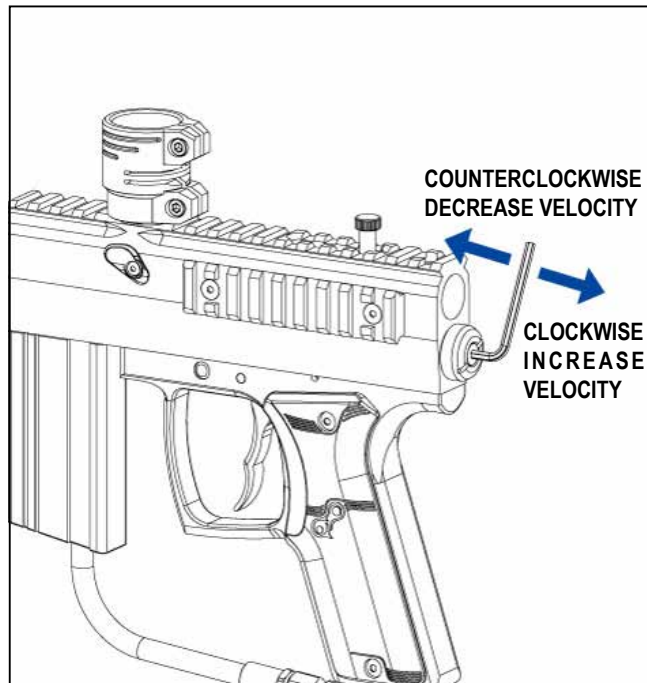

To increase your velocity FPS (Feet Per Second), use the allen wrench to turn the Velocity Adjuster (P023) clockwise.

To decrease your velocity FPS (Feet Per Second), use the allen wrench to turn the Velocity Adjuster (P023) anticlockwise.

ASSEMBLY AND CLEANING

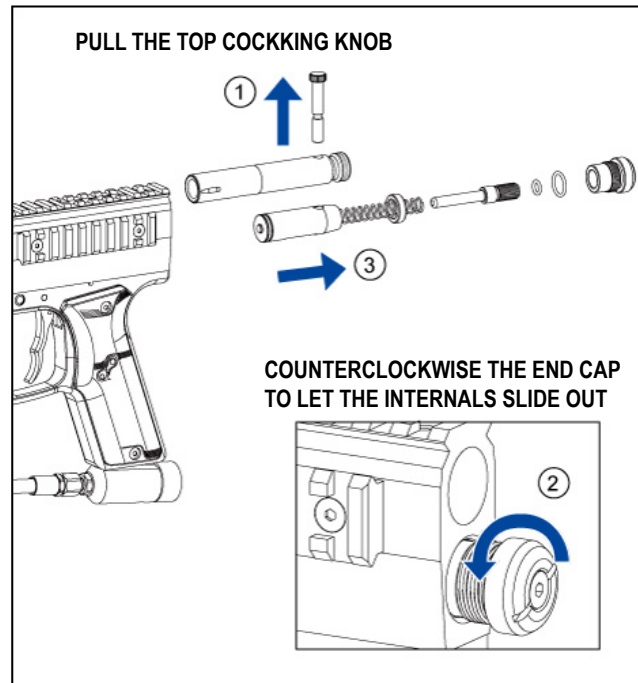

WARNING: Never remove the internals of the marker while the air tank is attached with the marker. Always remove all paintballs, loader and air tank before disassembling the marker.

CLEANING AND DISASSEMBLE REAR INTERNALS

1. Lift upward on the Top Cocking Knob at the rear of Delrin Bolt. This will let the Delrin Bolt (P041) slide out from the rear of the receiver.
2. Turn the End Cap (A051) counterclockwise. This will let the End Cap (A051) and the marker's internals to slide out from the rear of the receiver. Remember to place the marker in the de-cock position and place light pressure behind the End Cap during the removal of the End Cap, this way will prevent the internals to spring out.
3. Slide the Feather Striker (P021) out of the rear of the receiver.
4. Once all the internal parts are removed, use a squeegee to clean the inside of the receiver and use a towel to clean the dirt or paint of Delrin bolt. Apply some paintball gun oil on the Striker O-Ring regularly.

REASSEMBLE REAR INTERNALS

1. Insert the Striker (PT21) thru the rear of the receiver with the O-Ring facing towards the front of the marker and with the hole on the Striker facing upright. While inserting the Striker, apply pressure behind the Striker and at the same time pull the Trigger to let Striker enter the rear chamber of the receiver.
2. Insert the Bumper (P024) thru the receiver and insert the Striker Spring (P022) thru the Bumper.
3. Insert the End Cap (A052) with the Velocity Adjuster (P023) Thru the Bumper and Striker Spring.
4. Turn the End Cap (A052) clockwise to tighten it and hold the internals in place.
5. Insert the Bolt Assembly (P041) thru the rear of the receiver. Press downward on the Top Cocking Knob (At the rear of Bolt Assembly) to connect and enter the hole of Striker to fasten with the Striker. Use a small tool such as allen wrench to align the hole of the Striker.

TROUBLESHOOTING

WARNING: Always remove all paintballs, loader and air tank before disassembling the marker.

RECOCKING ISSUES

Need Lubrication on the Striker O-Ring (R011).

Striker O-Ring is damaged or missing. Replace a correct O-Ring.

The pressure in the tank is too low and needed to be refilled.

Dirt or broken paintball shell fragments in the receiver. Check, cleaning, and disassemble rear internals.

AIR LEAKS

Air leaking from the low pressure chamber. Check Front Valve O-Ring (R012), replace and apply 1-2 drops of paintball gun oil at this O-Ring.

Air leaking from under the barrel is normally caused by worn or damaged cup seal (P013). Check the guide for removal of Cup Seal / Valve Body.









A scratch on the Valve Body will cause air leak.



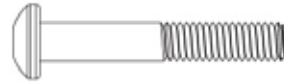



Air leaking from the receiver and throughout the Grip frame. Check Valve O-Rings and replace.

Air Leaking at opposite end of the hose fittings:

The Female end of the hose should have a plastic Seal Washer (P062) installed inside the hose collar and be sure to tighten it properly.

The Male end of the hose should have a Braided Hose O-Ring (R014) at the end of the male side of the hose. Replace the O-Ring if it is damaged.

ATS SCREW CHART SIZE: 1:1	PART NUMBER AND NAME
	S011 M5 X 10L MAIN BODY SCREW
	S012 M8 X 8L VALVE RETAINING SCREW
	S013 M5 X 30L BOTTOM ASA SCREW
	S015 M3 X 3L DETENT COVER SCREW
	S012 M4 X 8L GRIP PANEL SCREW
	S017 M5 X 12L FRONT PLUG SCREW
	S018 M4 X 8L SIDE RAILS SCREW
	S042 M4 X 70L FOREGRIP SCREW

ATS O-RING CHART SIZE: 1:1	PART NUMBER AND NAME
	R011 STRIKER O-RING (RED)
	R012 FRONT VALVE O-RING (CLEAR)
	R013 VELOCITY ADJUSTER O-RING (BLACK)
	R015 AZ O-RING (BLACK)
	R016 BARREL O-RING (BLACK)
	R017 END CAP O-RING (BLACK)

ATS EXPLODED VIEW

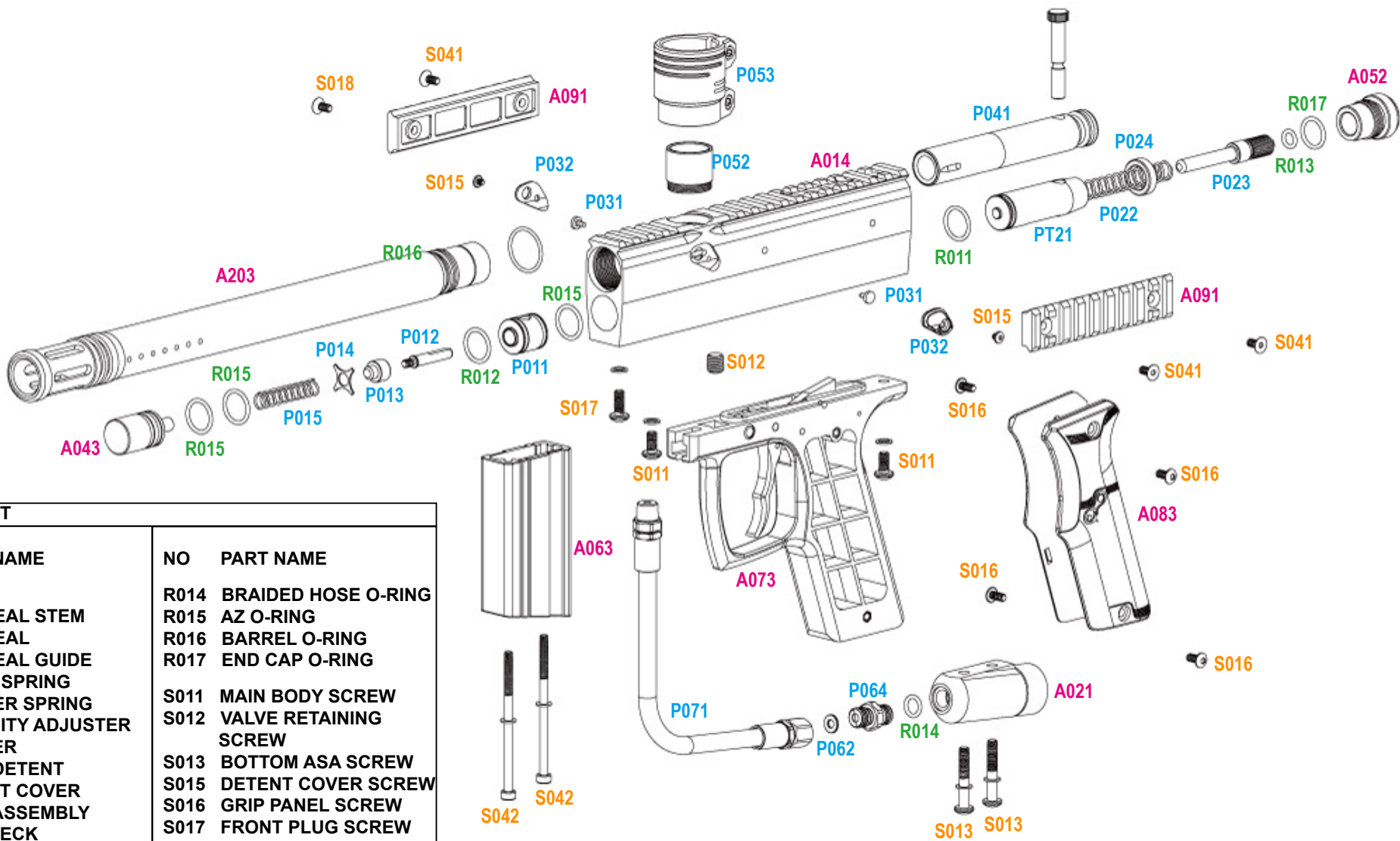



ATS PART LIST

NO	PART NAME	NO	PART NAME
P011	VALVE	R014	BRAIDED HOSE O-RING
P012	CUP SEAL STEM	R015	AZ O-RING
P013	CUP SEAL	R016	BARREL O-RING
P014	CUP SEAL GUIDE	R017	END CAP O-RING
P015	VALVE SPRING	S011	MAIN BODY SCREW
P022	STRIKER SPRING	S012	VALVE RETAINING SCREW
P023	VELOCITY ADJUSTER	S013	BOTTOM ASA SCREW
P024	BUMPER	S015	DETENT COVER SCREW
P031	BALL DETENT	S016	GRIP PANEL SCREW
P032	DETENT COVER	S017	FRONT PLUG SCREW
P041	BOLT ASSEMBLY	S018	SIDE RAIL SCREW
P052	FEEDNECK	S042	FOREGRIP SCREW
P053	SCREW LOCK ELBOW	A014	ATS BODY
P062	SEAL WASHER	A021	BOTTOM ASA
P064	STRAIGHT ELBOW	A043	FRONT PLUG
P071	BRAIDED HOSE	A052	END CAP
PT21	STRIKER	A063	FOREGRIP
R011	STRIKER O-RING (RED)	A073	GRIP FRAME ASSEMBLY
R012	FRONT VALVE O-RING (CLEAR)	A083	GRIP PANEL
R013	VELOCITY ADJUSTER O-RING	A091	SIDE RAILS
		A203	12" BARREL

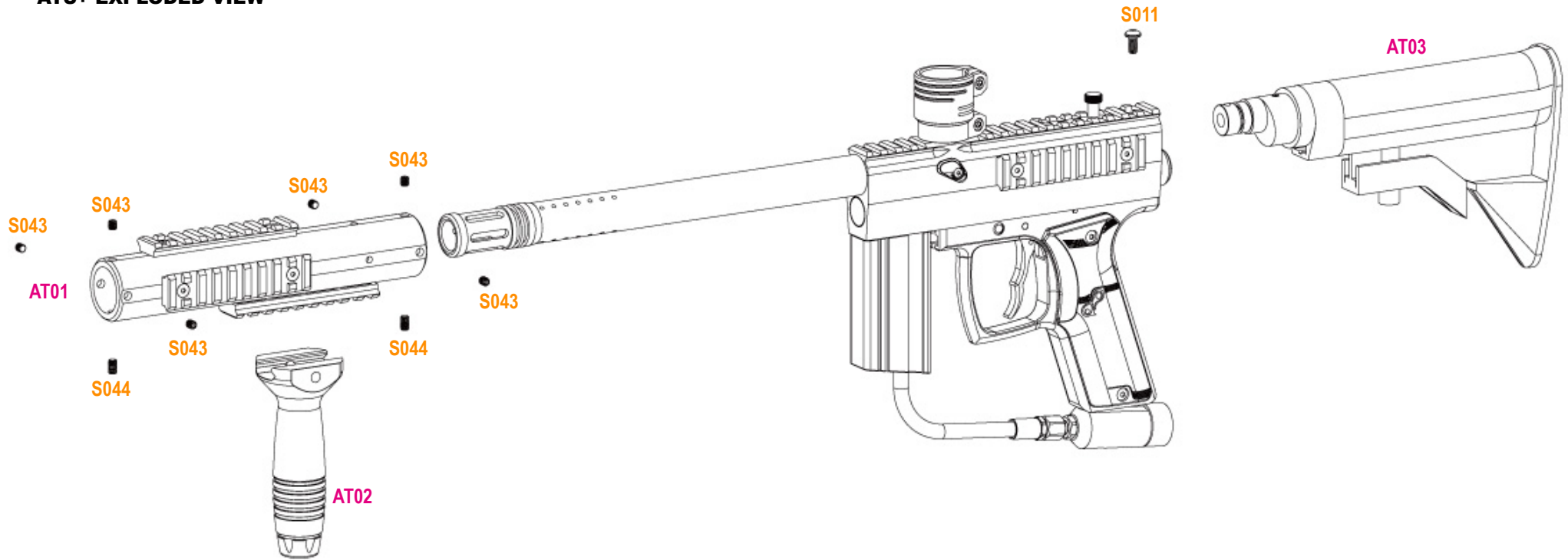
ATS+ EXPLODED VIEW



ATS+ SCREW CHART SIZE: 1:1	PART NUMBER AND NAME
	S043 M5 X 5L SHROUD RETAINING SIDE SCREW
	S044 M5 X 8L SHROUD RETAINING BOTTOM SCREW
	S011 M5 X 10L MAIN BODY SCREW

ATS+ PARTS LIST	
NO	PARTS NAME
S011	MAIN BODY SCREW
S043	SHROUD RETAINING SIDE SCREW
S044	SHROUD RETAINING BOTTOM SCREW
AT01	SHROUD
AT02	VERTICAL HANDLE
AT03	M16 STOCK