

!WARNING!

IMPORTANT SAFETY INSTRUCTION AND GUIDELINES

- This Paintball Marker is NOT A TOY. Misuse can cause serious injury or death.
- Recommend 18 years or older to purchase this product. Person under 18 must have adult supervision.
- Read this manual, understand and follow the manual instructions for using this product.
- Eye and face protection specially designed for paintball use, must be worn by user and persons within range at all times.
- Treat all paintball markers as if it were loaded and able to fire.
- Never look down the barrel or breech area of a marker.
- Always use barrel blocking device when the marker is not in use.
- Always chronograph this marker before playing paintball.
- Never shoot any marker at velocities exceeds 300 FPS (Feet Per Second), or velocities which is greater than local fields or national laws allow.
- Ensure all air lines and fittings are tightened and secured before installing the air tank.
- Do not shoot at people, animals, houses, cars or anything is not related to the sport of paintball.
- Always keep the marker in Safe mode until ready for use.
- Fire only 0.68 caliber paintballs with this marker.
- Always make sure the bolt is in the un-cocked position when marker is not in use.
- Any modifications or tampering of original factory parts will cause all warranties and liabilities from Azodin.
- This owner's manual should always accompany this marker for reference and in the event of resale and new ownership.

!WARNING!

IMPORTANT CO2/ HPA AIR TANK SAFETY INSTRUCTION AND GUIDELINES

- Tank valves must be installed or removed by qualified personnel.
- All tanks must be retested before the expiration date.
- Improper use, filling, storage of this air tank may cause death, serious injury and property damage.
- Air tanks must be filled only by properly trained personnel.
- Do not over pressurize. Do not expose pressurized tanks to temperatures in excess of 130F° degrees (54°C).
- Do not expose tanks to corrosive materials and do not clean with caustic cleaners.
- Do not alter tanks in any way.
- Tanks heated up to a temperature of 250F° degrees (54°C) or more must be condemned or re-qualified.
- Keep air tanks out of reach of children.
- The valve should NEVER detach from the tank canister. Should this occur, seek assistance from a qualified airsmith immediately.
- Air tanks are use for the sport of paintball only.

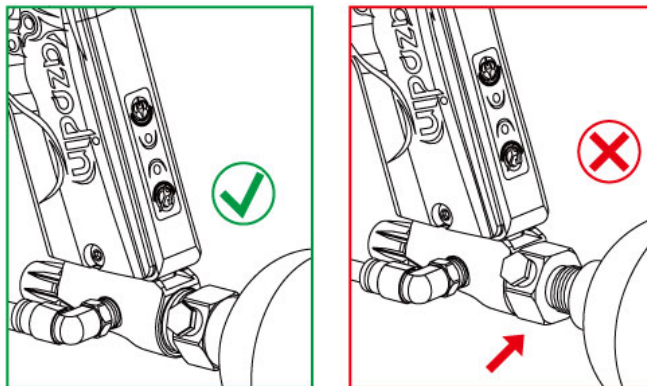

STOP IMMEDIATELY

CO2 or HPA/ N2 Air tanks will have enough force to fly off and cause serious injury or death if the valve unscrews from the tank head.

Look at the valve when removing the tank from the marker's Bottom ASA (A021). Make sure that the valve is turning with the tank instead of staying with the marker.

STOP IMMEDIATELY if valve starts to unscrew from the tank itself. Screw the tank back onto the marker's Bottom ASA adapter and contact a qualified airsmith for further assistance.

GETTING STARTED

1. First, place the BARREL BLOCKING DEVICE over the barrel.
2. Always point your marker at a "SAFE" direction before use. To use, press the Top Button once on the back of the grip frame. Doing this the Upper LED will show Red Light and the marker will be in Safe Mode. To unlock from the Safe Mode, point the marker in a Safe Direction, and press the Bottom Button once. Doing this the Upper LED will show Green Light and the marker will be ready to paly.
 - * For detailed operation of the electronics please refer to page (7)
3. Firmly screw in the CO2/ HPA/ N2 air tank to the Bottom ASA (A091). Tighten the air tank clockwise all the way in the marker's Bottom ASA.
CAUTION: Never use any hand tool to screw air tank to the bottom ASA.
4. Attach a paintball hopper/ loader to the marker's feed neck.
5. Remove the barrel blocking device and unlock the safe mode.
CAUTION: Now the marker is LIVE, pulling the trigger will fire a paintball. Only test your marker at the safe direction or in a proper organized paintball field.
6. Check marker's velocity FPS (Feet Per Second). Turning the Velocity Adjuster (P023) clockwise will increase the velocity. Counterclockwise will decrease the velocity.
7. After playing, take out all paintballs from the hopper. Then detach the hopper from the marker.
CAUTION: There may be 1-2 paintballs in the breach area; take a couple more shots in a safe direction to make sure the marker is empty of paintballs.
8. Place the barrel blocking device over the barrel and push the safety button in the safe mode.
9. Unscrew the CO2/ HPA/ N2 air tanks from the marker's bottom ASA.
CAUTION: Never use any hand tool to screw air tanks to the bottom ASA.
10. Store the marker in a paintball gear bag or in a safe place.

USING THE ZEN BOARD

TO TURN ON THE BOARD: Press the Top Button once to turn on the board. Upper LED will show **Red Light (Safe Mode)** and Lower LED will show **Green Light (Default setting is Semi-Auto mode)** If Upper LED Light is flashing **Red Light**, it means battery power status is low and the battery needs to be change. Battery power status can be verified by press Top Button once more to confirm.

SAFF MODE: After turning on the board, press Lower Button once to turn off the Safe Mode and Upper LED Light will show **Green Light** to indicate the Eyes are on. Press Lower Button again to turn on the Safe Mode. Right now the Upper LED Light will show **Red Light** to indicate the Safe Mode is on.

EYES ON/OFF: When Safety is on and Upper LED Light is showing **Green Light (Eyes On)**, press the Top Button once and Upper LED Light will change to **Orange Light** to indicate the eyes are off. To turn the eyes back On, press Top Button again and Upper LED Light will showing **Green Light** again to indicate the Eyes are back on. When there is a ball break or Eyes are malfunction, Upper LED Light will **Flash Green Light**. Now press Top Button to turn off the Eyes and press Top Button again to turn the back Eyes on to determine the problem. If the Upper LED light still **Flash Green Light**, clean out the Eyes.

FIRE MODE LOCK: To lock the marker in desired fire mode, a small **Red Circuit Jumper** needs to be removed from the Circuit Board. Circuit Board will memorize the last fire mode setting when the "**Jumper**" has been removed or it will back to default Semi-Auto again. To re-enable all firing modes, simply place the Cricuit Jumper back onto the Circuit Board.

LED COLORS
UPPER LED
RED = SAFF MODE
GREEN = EYES ON
ORANGE = EYES OFF (10.5 BPS)
FLASH RED = LOW BATTERY POWER STATUS
FALSH GREEN = EYES MALFUNCTION (8 BPS)
LOWER LED
GREEN = SEMI - AUTO (20 BPS SS = 0)
DARK BLUE = PSP RAMP (12.5 BPS SS = 0)
PURPLE = MILLENIUM RAMP (10.5 BPS SS = 3)
LIGHT BLUE = CFOA SEMI (10.5 BPS SS V= 3)
FALSH GREEN = PROGRAMMING MODE

NOTE: Safety Shot (SS) defines the number of consecutive trigger pulls that must be achieved in order to activate the fire mode.

BUTTONS
TOP BUTTON
PRESS ONCE = POWER ON
PRESS AGAIN = VERIFY BATTERY POWER STATUS
PRESS AGAIN = EYES ON/OFF
PRESS AND HOLD = TURN OFF
LOWER BOTTON
PRESS ONCE = SAFF MODE ON/OFF
PRESS AND HOLD = ENTERS PROGRAMMING MODE
IN PROGRAMMING MODE
PRESS ONCE = CYCLE THROUGH SHOOTING MODES
PRESS AND HOLD = CONFIRM SHOOTING MODES

VELOCITY ADJUSTMENTS

(INCREASE & DECREASE VELOCITY)

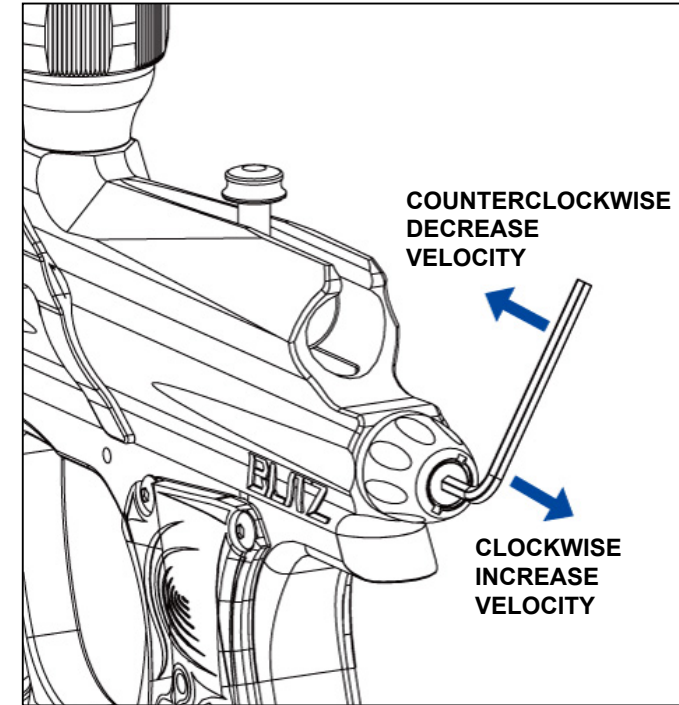

To increase your velocity FPS (Feet Per Second), use the allen wrench to turn the Velocity Adjuster (P023) clockwise.

To decrease your velocity FPS (Feet Per Second), use the allen wrench to turn the Velocity Adjuster (P023) counterclockwise.

REGULATOR ADJUSTMENT

(INCREASE & DECREASE AIR PRESSURE)

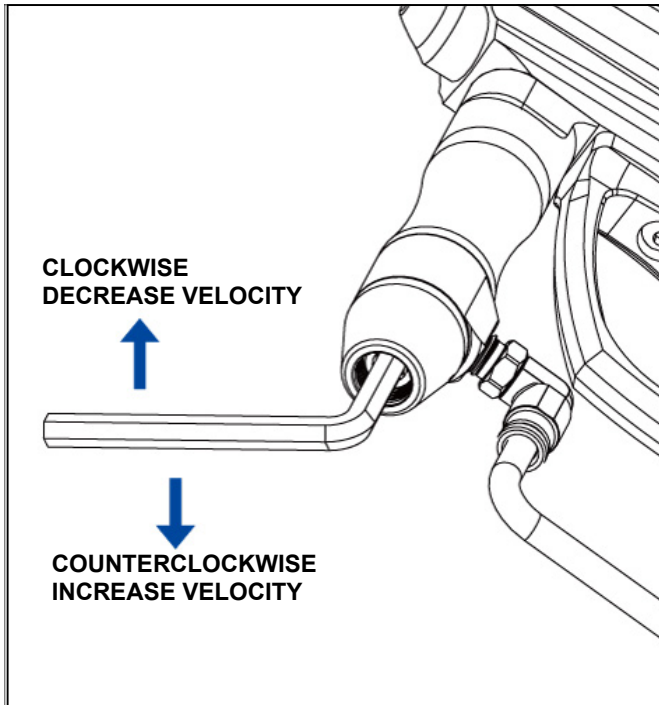

To increase the input pressure use the allen wrench to turn the Regulator Adjustment Screw (S032) counterclockwise.

To decrease the input pressure use the allen wrench to turn the Regulator Adjustment Screw (S032) clockwise.

NOTE: Regulator is preset at the factory for optimum performance. Fine adjustment of velocity should be done with the Velocity Adjustor (P023) on page 9.

NOTE: Each quarter turn correspond to apporximate increase or decrease of 20psi.

ASSEMBLY AND CLEANING

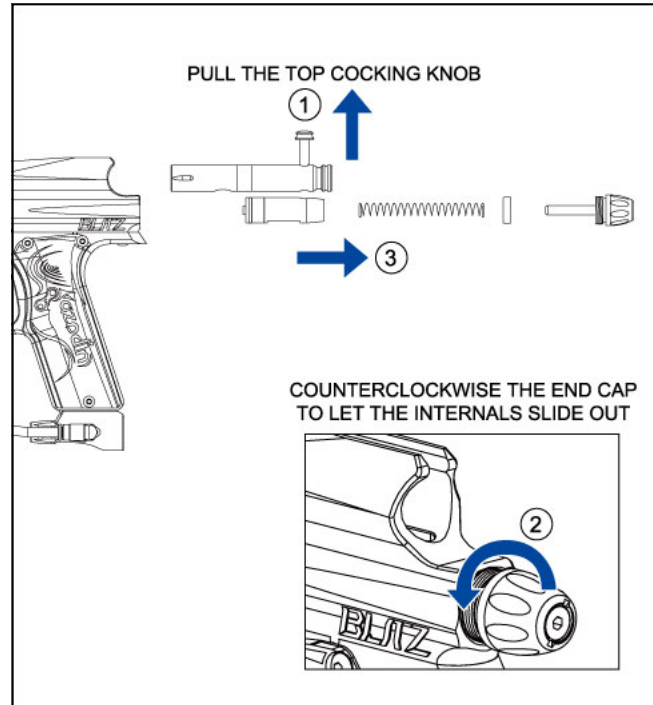

WARNING: Never remove the internals of the marker while the air tank is attached with the marker. Always remove all paintballs, loader and air tank before disassembling the marker.

CLEANING AND DISASSEMBLE REAR INTERNALS

1. Lift upward on the Top Cocking Knob at the rear of Delrin Bolt. This will let the Delrin Bolt (P042) slide out from the rear of the receiver.
2. Turn the End Cap (A051) counterclockwise. This will let the End Cap and the marker's internals to slide out from the rear of the receiver. Remember to place the marker in the de-cock position and place light pressure behind the End Cap during the removal of the End Cap, this way will prevent the internals to spring out.
3. Slide the Feather Striker (P021) out of the rear of the receiver.
4. Once all the internal parts are removed, use a squeegee to clean the inside of the receiver and use a towel to clean the dirt or paint of Delrin bolt. Apply some paintball gun oil on the Striker O-Ring regularly.

REASSEMBLE REAR INTERNALS

1. Insert the Feather Striker (P021) thru the rear of the receiver with the O-Ring facing towards the front of the marker and with the hole on the Feather Striker facing upright. While inserting the Feather Striker, apply pressure behind the Feather Striker and at the same time pull the Trigger to let Feather Striker enter the rear chamber of the receiver.
2. Insert the Feather Bumper (P024) thru the receiver and insert the Feather Spring (P022) thru the Feather Bumper.
3. Insert the End Cap (A051) with the Velocity Adjuster (P023) Thru the Feather Bumper and Feather Spring.
4. Turn the End Cap (A051) colckwise to tighten it and hold the internals in place.
5. Insert the Bolt Assembly (P042) thru the rear of the receiver. Press downward on the Top Cocking Knob (At the rear of Bolt Assembly) to connect and enter the hole of Feather Striker to fasten with the Feather Striker. Use a small tool such as allen wrench to align the hole of the Feather Striker.

TROUBLESHOOTING

WARNING: Always remove all paintballs, loader and air tank before disassembling the marker.

RECOCKING ISSUES

Need Lubrication on the Striker O-Ring (R011).

Striker O-Ring is damaged or missing. Replace a correct O-Ring.

The pressure in the tank is too low and needed to be refilled.

Dirt or broken paintball shell fragments in the receiver. Check, cleaning, and disassemble rear internals.









AIR LEAKS

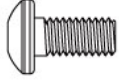

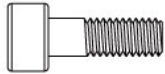

Air leaking from the low pressure chamber. Check Front Valve O-Ring (R012), replace and apply 1-2 drops of paintball gun oil at this O-Ring.

Air leaking from under the barrel is normally caused by worn or damaged cup seal (PH13). Check the guide for removal of Cup Seal / Valve Body.

A scratch on the Valve Body will cause air leak.

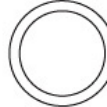
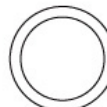
Air leaking from the receiver and throughout the Grip frame. Check Valve O-Rings and replace.

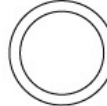
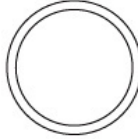
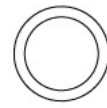
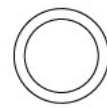
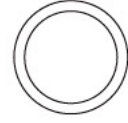
BLITZ SCREW CHART SIZE: 1:1	PART NUMBER AND NAME
	S011 M5 X 10L MAIN BODY SCREW
	S012 M8 X 8L VALVE RETAINING SCREW
	S016 M4 X 8L GRIP PANEL SCREW
	S017 M5 X 14L VERTICAL ASA SCREW
	S018 M4 X 8L EYE COVER SCREW
	S031 M4 X 4 RETAINING SCREW
	S091 M12 X 8L ON/OFF BOTTOM ASA RETAINING SCREW
	S092 1/8-27 NPT ON/OFF BOTTOM ASA HOSE PLUG
	S093 M5 X 12L ON/OFF BOTTOM ASA SCREW

BLITZ O-RING CHART SIZE: 1:1	PART NUMBER AND NAME
	R011 STRIKER O-RING (RED)
	R012 FORNT VALVE O-RING (CLEAR)
	R013 VELOCITY ADJUSTER O-RING (BLACK)
	R015 AZ O-RING (BLACK)
	R016 BARREL O-RING (BLACK)
	R017 END CAP O-RING (BLACK)
	R031 REGULATOR PISTON O-RING (CLEAR)
	R032 REGULATOR SWIVEL MOUNT O-RING (BLACK)
	R033 INNER O-RING (CLEAR)
	R034 REGULATOR SEAL O-RING (CLEAR)

A062 INLINE REGULATOR

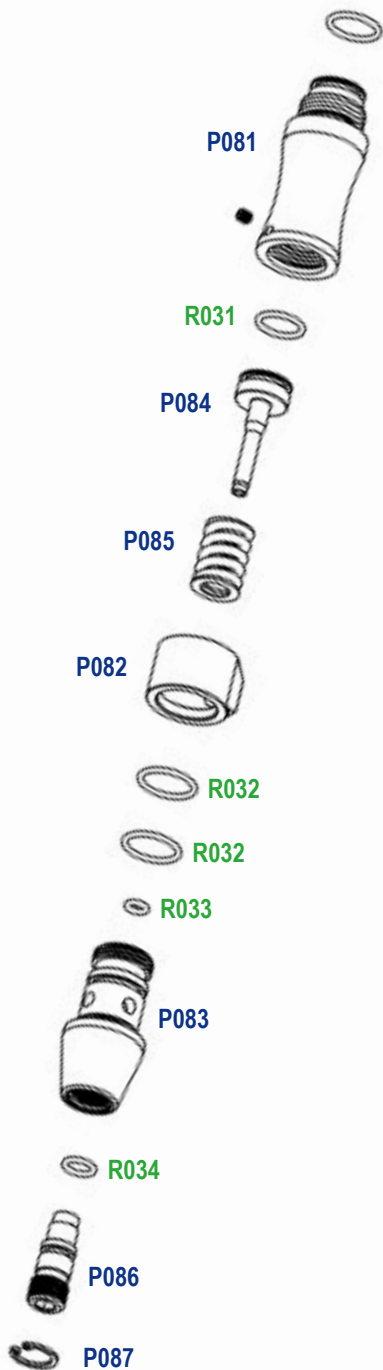

REGULATOR PARTS LIST

NO	PART NAME
P081	MAIN REGULATOR HOUSING
P082	REGULATOR SWIVEL MOUNT
P083	REGULATOR END CAP
P084	REGULATOR PISTON
P085	REGULATOR MAIN SPRING
P086	SEAT SEAL CARRIER
P087	C CLIP
R015	AZ O-RING
R031	REGULATOR PISTON O-RING
R032	REGULATOR SWIVEL MOUNT O-RING
R033	REGULATOR INNER O-RING
R034	REGULATOR SEAL O-RING
S031	RETAINING SCREW

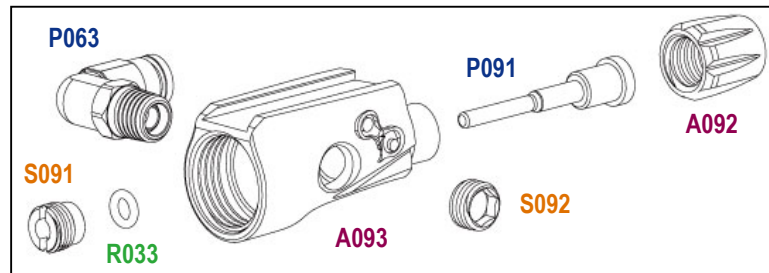

ON/OFF BOTTOM ASA PARTS LIST

NO	PART NAME
P063	90 DEGREE ELBOW
P091	ON/OFF BOTTOM ASA STEM
R033	INNER O-RING
S091	ON/OFF BOTTOM ASA RETAINING SCREW
S092	ON/OFF BOTTOM ASA HOSE PLUG
A092	ON/OFF BOTTOM ASA CAP
A093	ON/OFF BOTTOM ASA MAIN BODY

BLITZ PARTS LIST

NO	PART NAME	NO	PART NAME
PH11	HP VALVE	R015	AZ O-RING
PH12	HP CUP SEAL STEM	R016	BARREL O-RING
PH13	HP CUP SEAL	R017	END CAP O-RING
P014	CUP SEAL GUIDE	S011	MAIN BODY SCREW
P015	VALVE SPRING	S012	VALVE RETAINING SCREW
P021	FEATHER STRIKER	S016	GRIP PANEL SCREW
P022	FEATHER SPRING	S017	VERTICAL ASA SCREW
P023	VELOCITY ADJUSTER	S018	EYE COVER SCREW
P024	FEATHER BUMPER	A012	BLITZ BODY
P031	BALL DETENT	A032	VERTICAL ASA
P033	EYE COVERS	A041	FRONT PLUG
P042	BOLT ASSEMBLY	A051	END CAP
P051	TWIST LOCK FEEDNECK	A062	REGULATOR
P063	90 DEGREE MACROLINE ELBOW	A072	E-GRIP FRAME ASSEMBLY
P072	MACROLINE HOSE	A082	GRIP PANEL
R011	STRIKER O-RING (RED)	A091	ON/OFF BOTTOM ASA
R012	FRONT VALVE O-RING (CLEAR)	A201	12" BARREL
R013	VELOCITY ADJUSTER O-RING	E010	ZEN BOARD

BLITZ-EVO EXPLODED VIEW

